

Quick Start Guide

SenseFace 7 Series

Version: 1.0

1. Overview

SenseFace 7A / 7C

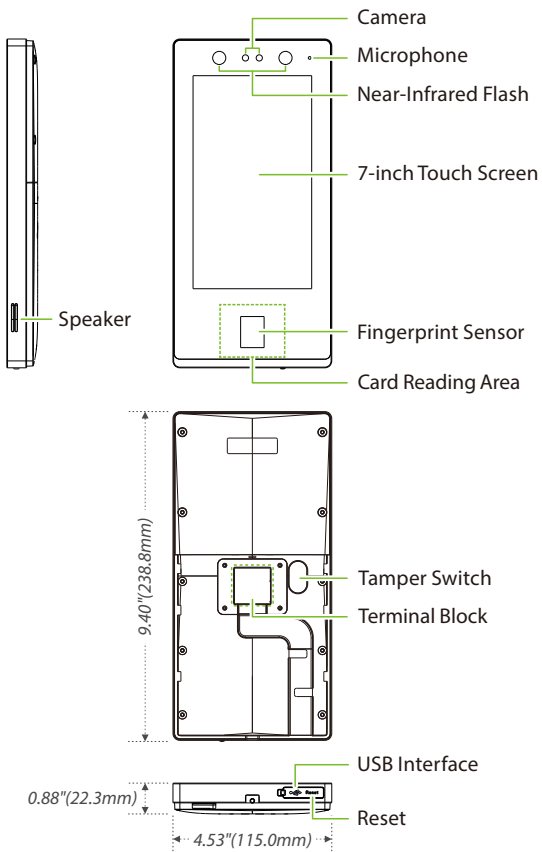

SenseFace 7B

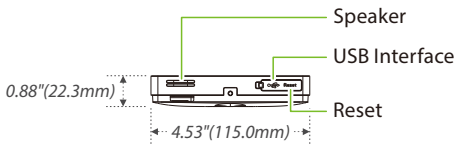
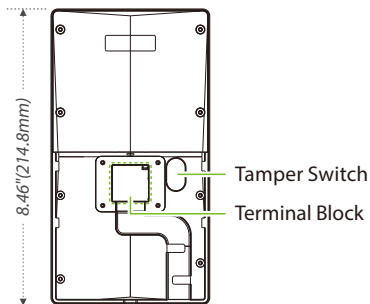
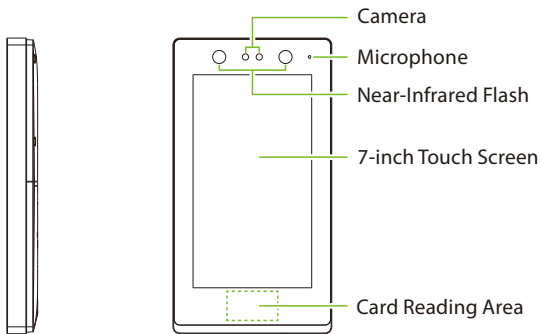

Note: Not all products have the function with ★, the real product shall prevail.

2. Installation Environment



INSTALL INDOORS
ONLY



AVOID INSTALLATION
NEAR
GLASS WINDOWS



AVOID DIRECT
SUNLIGHT
AND EXPOSURE



AVOID USE OF ANY
HEAT SOURCE
NEAR THE DEVICE

3. Device Installation

Install on the wall

- ① Attach the mounting template sticker to the wall, and drill holes according to the mounting paper.
- ② Fix the backplate on the wall with the wall mounting screws.
- ③ After passing the wires through the wiring hole and connecting them to the device, and then snap the device onto the backplate and push it down into place.
- ④ Fasten the device to the backplate with a security screw.

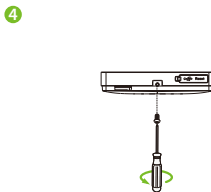
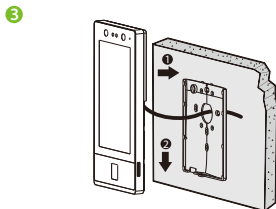
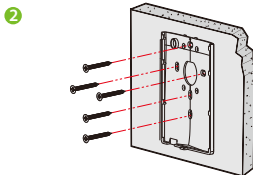
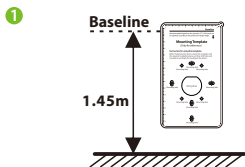

4. Standalone Installation

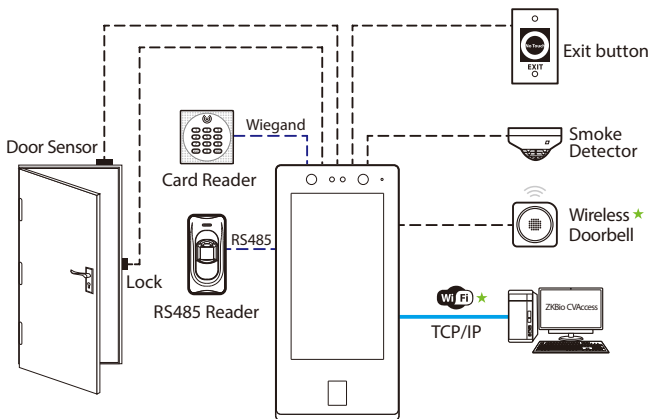

5. Terminal Block

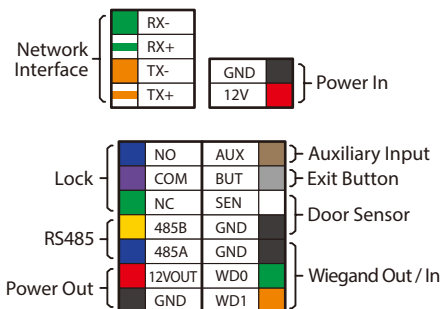
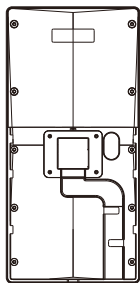

6. Ethernet Connection

Establish the connection between the device and the software using an Ethernet cable. An illustrative example is provided below:

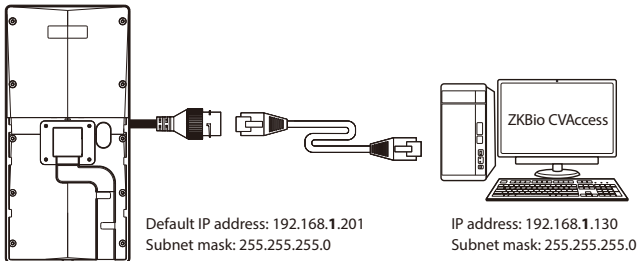

Tap on ☰ to enter the main menu. And then click on **[Comm.] > [Ethernet] > [IP Address]** to input the IP address.

Note: In LAN, IP addresses of the server (PC) and the device must be in the same network segment when connecting to the software.

7. Power Connection

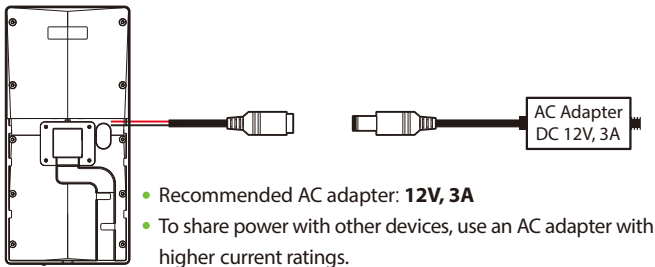

8. Exit Button, Door Sensor & Auxiliary Connection

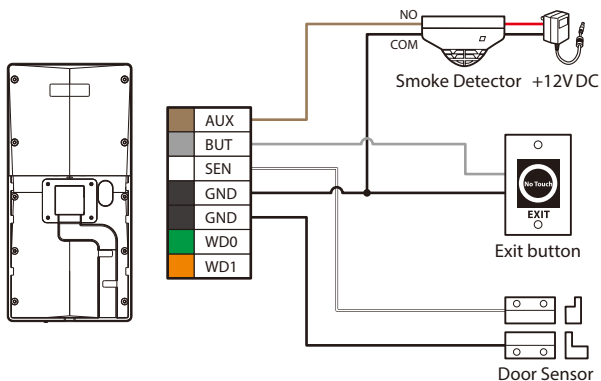

9. RS485 Connection

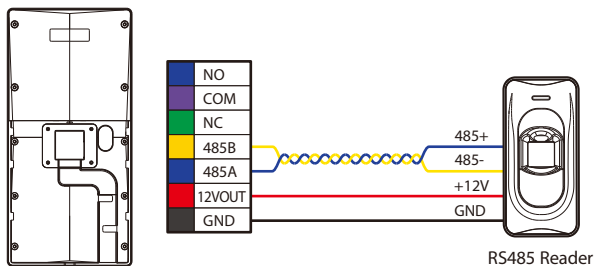

10. Lock Relay Connection

The system supports both **Normally Opened Lock** and **Normally Closed Lock**. The **NO LOCK** (normally opened at power on) is connected with 'NO' and 'COM' terminals, and the **NC LOCK** (normally closed at power on) is connected with 'NC' and 'COM' terminals. Take NC Lock as an example below:

1) Device not sharing power with the lock

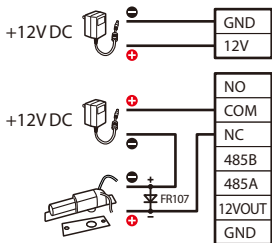

Normally Closed Lock

2) Device sharing power with the lock

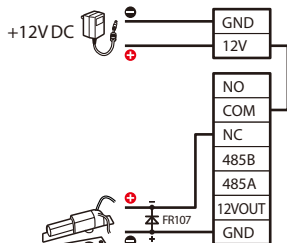

Normally Closed Lock

11. Wiegand Reader Connection

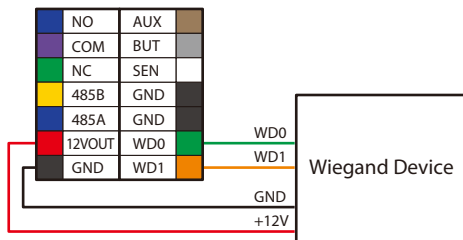
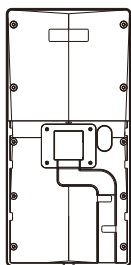

Note: The Wiegand interface is shared, and the user can choose to use either the Wiegand input or Wiegand output function to interface with different Wiegand devices.

12. User Registration

Click ☰ to enter the Main Menu screen. When a super administrator is set up, administrator verification is required when entering the menu. For security purposes, it is recommended to register a super administrator when using it for the first time.

Method 1: Registering on the device

Click ☰ > **[User Mgt.]** > **[New User]** to register a new user. The options include entering the user ID and Name, setting User Role and Access Control Role, registering Face, Fingerprint, Card Number, Password and Profile Photo.

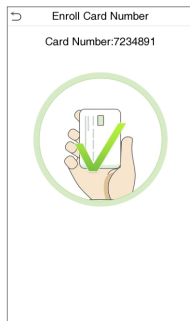
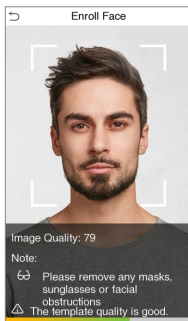
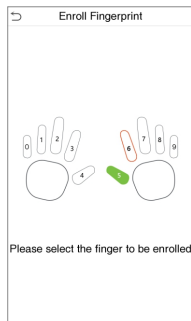
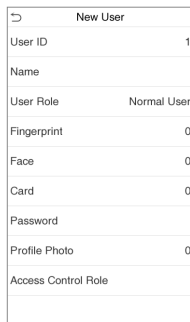
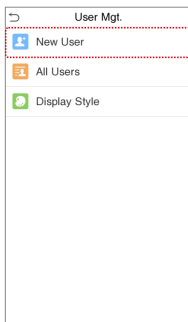
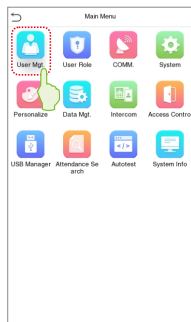

Method 2: Register on ZKBio CVAccess software

Please set the IP address and cloud service server address in the **COMM.** menu option on the device.

1. Click [**Access**] > [**Access Device**] > [**Device**] > [**Search**] to search the device on the software. When an appropriate server address and port is set on the device, the searched devices are displayed automatically.

The screenshot displays the 'Access / Access Device / Device' interface. At the top, there are input fields for 'Device Name', 'Serial Number', and 'IP Address', along with a 'More' menu and search icons. Below these are navigation buttons: Refresh, New, Delete, Export, Search, Control, Set up, View / Get, and Communication. A search window is open, showing a message 'No device found? Download Search Tools to Local Disk'. The search window has a 'Search' button (Step 1) and a 'Total Progress' indicator (Step 2). Below the search window is a table with columns: IP Address, MAC Address, Subnet Mask, Gateway Add..., Serial Number, Device Type, Set Server, and Operation. The first row contains the values: 192.168.137.32, 255.255.255.0, 192.168.137.1, 7273212700020, and an 'Add' button (Step 3). An 'Add' dialog box is open in the foreground, with fields for 'Device Name' (192.168.137.32), 'Icon Type' (Door), 'Area' (Area Name), and 'Add to Level'. It also has a 'Clear Data in the Device when Adding' checkbox and a warning message: '[Clear Data in the Device when Adding] will delete data in the device (except event record), please use with caution!'. The dialog has 'OK' (Step 4) and 'Cancel' buttons.

2. Click [**Add**] in operation column, a new window will pop-up. Select Icon type, Area, and Add to Level from each dropdowns and click [**OK**] to add the device.
3. Click [**Personnel**] > [**Person**] > [**New**] and fill in all the required fields to register a new users in the software.
4. Click [**Access**] > [**Device**] > [**Control**] > [**Synchronize All Data to Devices**] to synchronize all the data to the device including the new users.
For more details, please refer to the *ZKBio CVAccess User Manual*.

Method 3: Register on the phone

Once the ZKBio CVAcess software is installed, the users could enroll their face via a browser application on their own mobile phone.

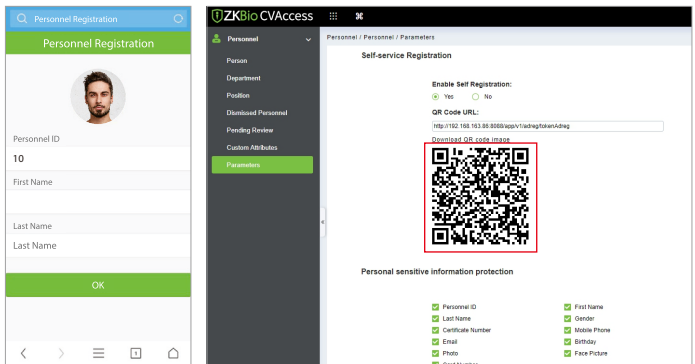

1. Click [**Personnel**] > [**Parameters**], input “http://Server address: Port” in the QR Code URL bar. The software will automatically generate a QR code. Scan the QR code or login onto “http://Server address: Port/app/v1/adreg” by the mobile phone to register users.



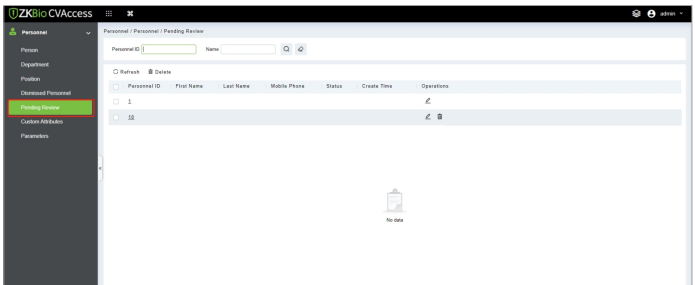

2. The users will be displayed in [**Personnel**] > [**Pending Review**].



13. Ethernet and Cloud Server Settings

Click  > [COMM.] > [Ethernet] to set the network parameters. If the TCP/IP communication of the device is successful, the  icon will be displayed in the upper right corner of the standby interface.

Click  > [COMM.] > [Cloud Server Setting] to set the server address and server port, that is, the IP address and port number of the server after the software is installed. If the device communicates with the server successfully, the icon  will be displayed in the upper right corner of the standby interface.

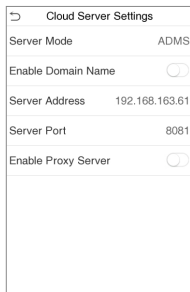
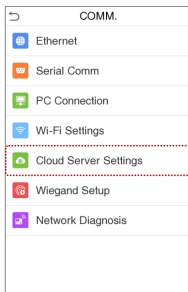
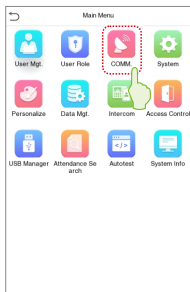
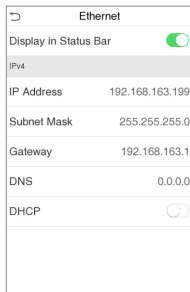
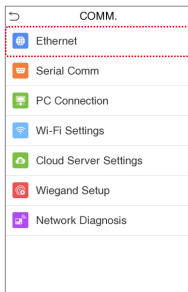
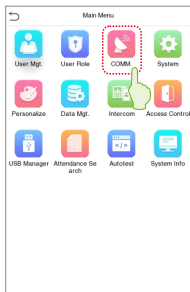

Note: While pairing the device with ZKBio CVAccess software. Make sure that the option **Enable Domain Name** is disabled and the correct server address and port are entered.

14. Configuring Wi-Fi★

Click ☰ > [COMM.] > [Wi-Fi Settings] to configuring Wi-Fi. When Wi-Fi is enabled, select the searched network. Enter the password, and click **Connect to Wi-Fi (OK)**. The connection succeeds, with icon 📶 displayed on the status bar. You can also select **Add Wi-Fi Network** to add Wi-Fi manually.

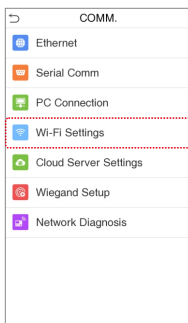
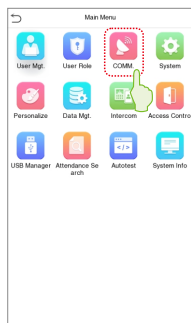

15. Connect the Wireless Doorbell★

This function needs to be used with the wireless doorbell.

First, power on the wireless doorbell. Then, press and hold the music button 🎵 for 1.5 seconds until the indicator flashes to indicate it's in pairing mode. After that, click on the device icon 📶, if the wireless doorbell rings and the indicator flashes, it means the connection is successful.

After a successful pairing, clicking the icon 📶 of the device will ring the wireless doorbell.

Note: Generally, each device connects to one wireless doorbell.

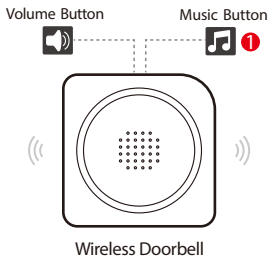
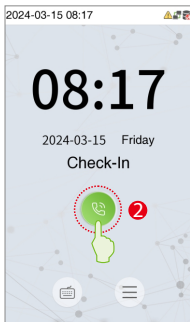

16. SIP Settings

Setting call options on the device

Click ☰ > [Intercom] > [SIP Settings] > [Call Options] to set the SIP common parameters.

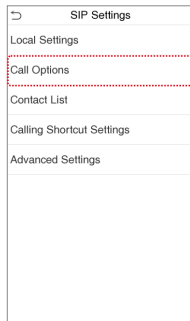
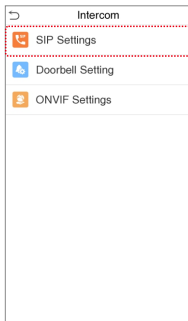
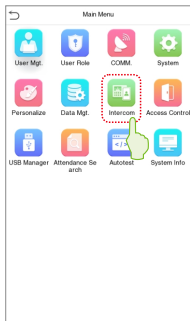

Mode 1: Local Area Network

Note: When the SIP Server function is enabled, the Contact List menu are not displayed. To use Contact List, turn off the SIP Server.

● Calling by IP Address

1. Set the IP address on the indoor station, Tap **[Menu]** > **[Advanced]** > **[Network]** > **[1. Network]** > **[1. IPv4]**.

Note: Indoor station IP address and the device IP address must be in the same network segment.

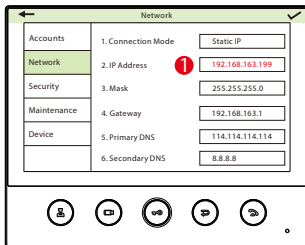

2. Click  icon on the standby page to enter the call page, users can call the IP address of the indoor station.

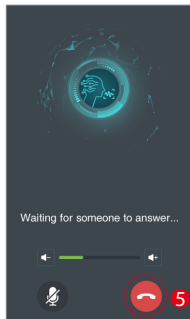
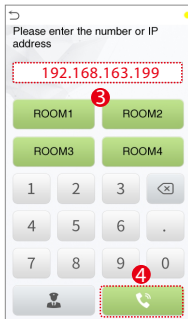
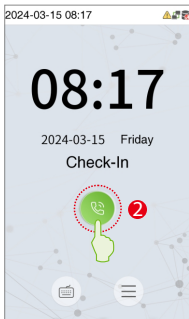

● Calling by Shortcut

1. Click ☰ > [Intercom] > [SIP Settings] > [Contact List].
2. Click [Add], input device number and call address to add a new contact member.
Note: Call address and the device must be in the same network segment.
3. Click [SIP Settings] > [Calling Shortcut Settings], select any item except admin, and enter the form information you just uploaded.
4. Then you can enter the device number or click shortcut key in the call screen to directly implement the video intercom.

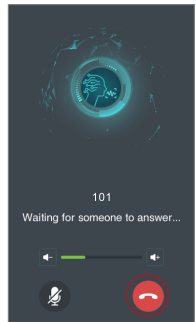
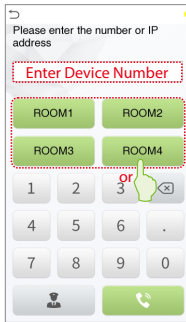
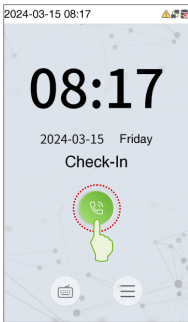

● Direct Calling Mode

1. Click ☰ > [Intercom] > [SIP Settings] > [Contact List].
2. Click [Add], input device number and call address to add a new contact member.
Note: Call address and the device must be in the same network segment.
3. Click [SIP Settings] > [Calling Shortcut Settings] > [Call Mode] > [Direct Calling Mode] > [Add]. Select the IP addresses of the indoor stations that you want to call, then the indoor stations will be displayed in the list.
4. Then you can tap the 📞 icon on the device to call the indoor stations at the same time.

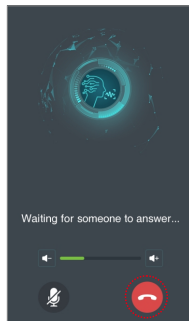
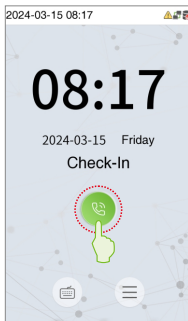
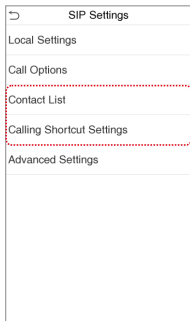

Mode 2: SIP Server

1. Click > [Intercom] > [SIP Settings] > [Local Settings] to enable the SIP server.
2. Click [Master Account Setting] / [Backup Account Setting] to set the SIP server parameters.
3. Click icon on the standby page to enter the call page, once the SIP is set up correctly, a green dot will appear in the upper right corner of the call page to indicate that the device is connected to the server. You can call the account name of the indoor station.

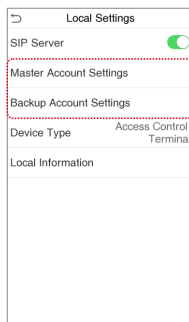
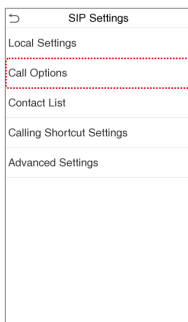
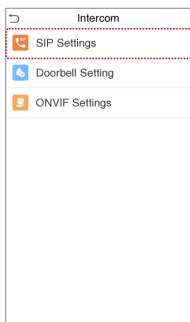

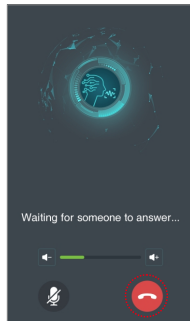
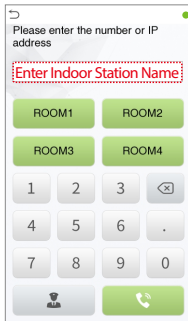
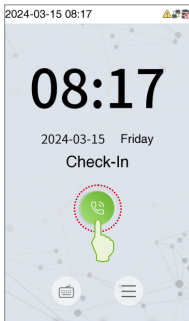

Note: When users need to enable SIP server, they need to purchase the server address and password from the distributor, or build the server confidently.

17. ONVIF Settings

This function needs to be used with the Network Video Recorder (NVR).

1. Set the device to the same network segment as the NVR.
2. Click ☰ > **[Intercom]** > **[ONVIF Settings]** to set the User Name and Password.

Note: If the Authentication function is disabled, then there is no need to input the User Name and Password when adding the device to the NVR.

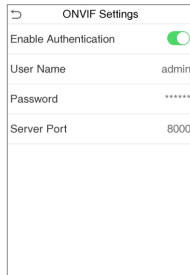
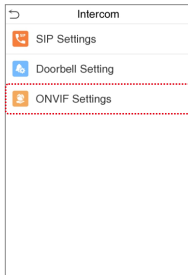
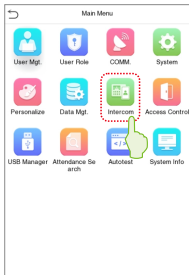

- On the NVR system, click **[Start]** > **[Menu]** > **[Channel Manage]** > **[Add Channel]** > **[Refresh]** to search for the device.

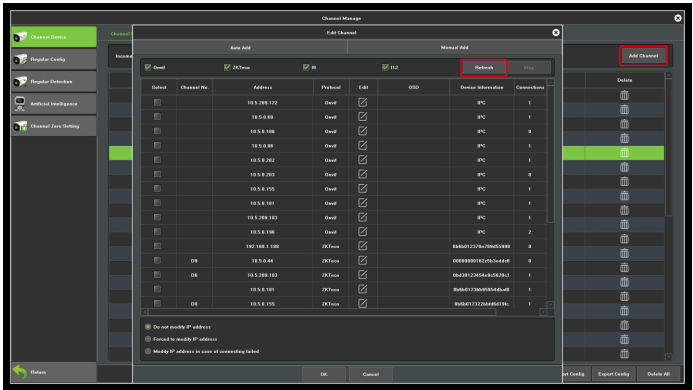

- Select the checkbox for the device you want to add and edit the parameters in the corresponding text field, then click on **[OK]** to add it to the connection list.

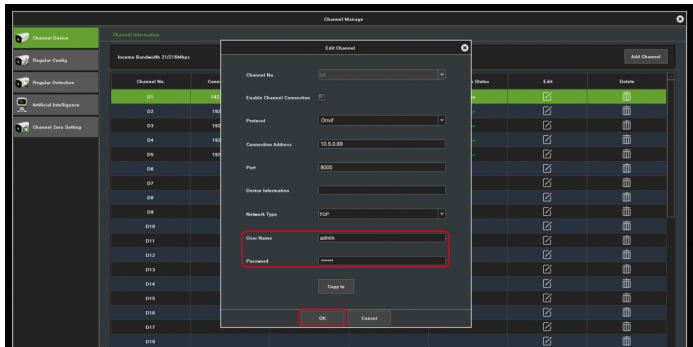

- After successfully adding, the video image obtaining from the device can be viewed in real-time. For more details, please refer to the *NVR User Manual*.

ZKTeco Industrial Park, No. 32, Industrial Road,
Tangxia Town, Dongguan, China.

Phone : +86 769 - 82109991

Fax : +86 755 - 89602394

www.zkteco.com

